

# Calculate sides in right-angled triangles using Pythagoras' Theorem

R



1 Use Pythagoras' Theorem to find the unknown lengths.

Give your answers to 1 decimal place.

a)

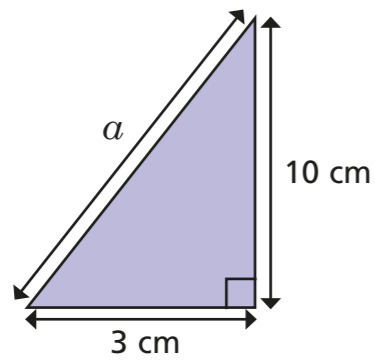

$a = \square$  cm

d)

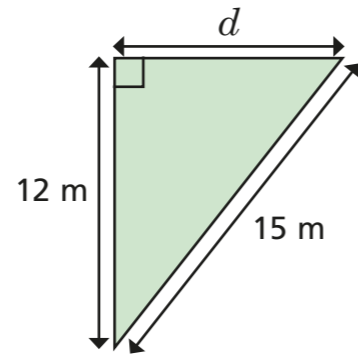

$d = \square$  m

b)

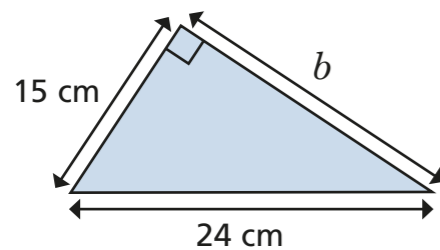

$b = \square$  cm

e)

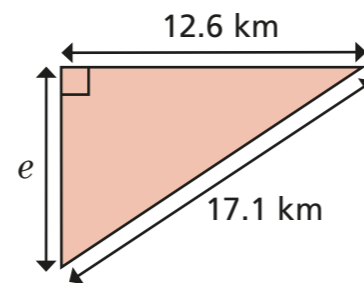

$e = \square$  km

c)

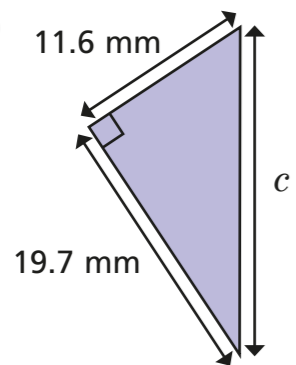

$c = \square$  mm

f)

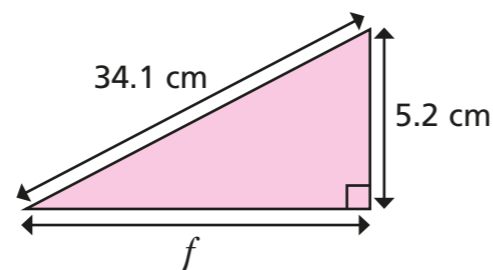

$f = \square$  cm

2

A right-angled triangle has sides with lengths of 12 cm and 13 cm. Find the two possible lengths of the third side.

and

3

This shape is made from three right-angled triangles. Work out the length of DE.

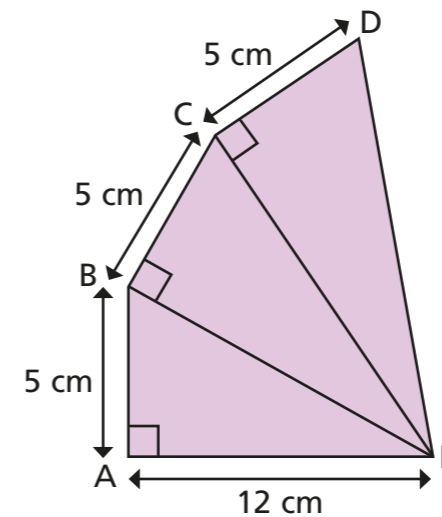

4

The minute hand of the Great Clock of Westminster is 14 feet long. Its hour hand is 9 feet long.

At 9 o'clock, how far is the tip of the hour hand from the tip of the minute hand?

Give your answer to the nearest foot.

feet

5 A logo is made of four congruent right-angled triangles.

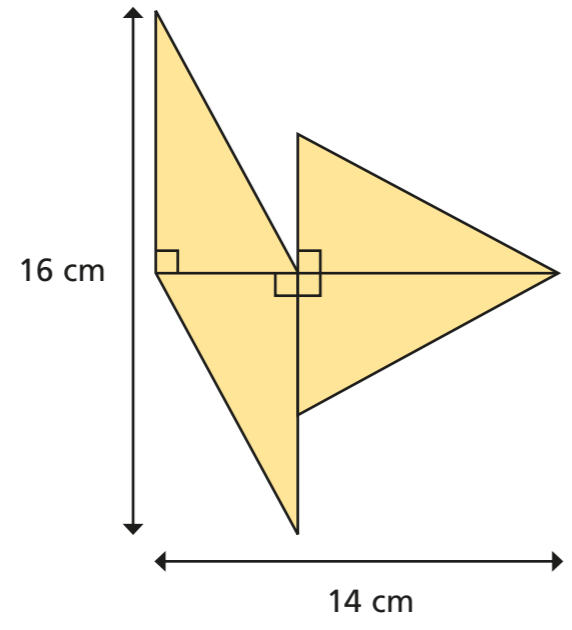

Work out the perimeter of the logo.

6 ABCD is a trapezium.  
Find the perimeter of the trapezium.  
Give your answer to 1 decimal place.

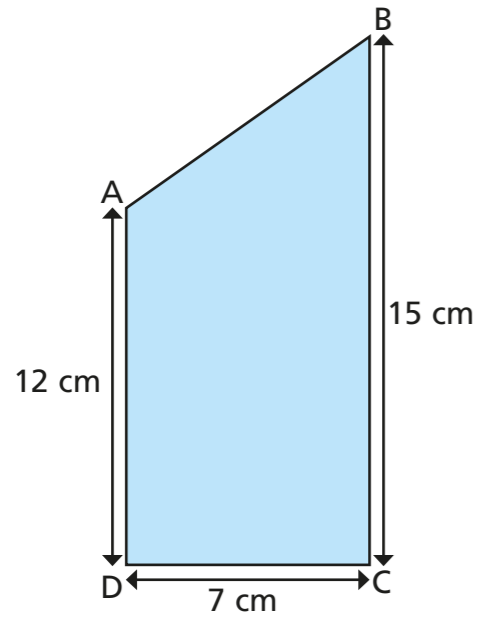



7 Points P and Q have the coordinates  $(-12, -19)$  and  $(23, 37)$ .  
Work out the length of the line segment PQ.

 units

8 Two rectangles are joined to form a compound shape.  
The two rectangles have the same perimeter.

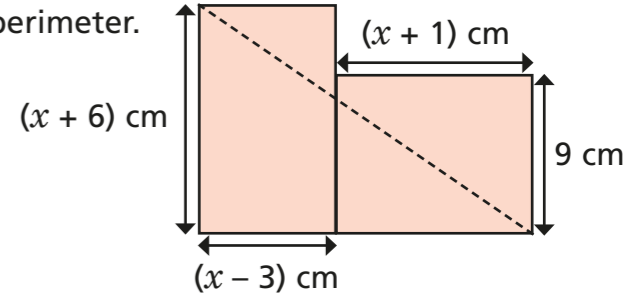
a) Work out the perimeter of the compound shape.



b) Work out the length of the diagonal marked.

9 The diagram shows two right-angled triangles.  
Form and solve an equation to find the value of  $x$ .

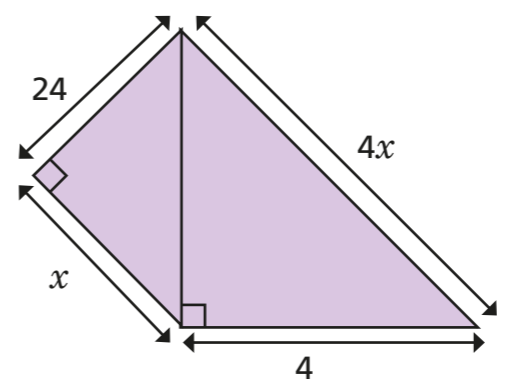
 $x =$